

**IT 002 – SOBRETENSÕES EM SISTEMAS
ELÉTRICOS DE POTENCIA.**

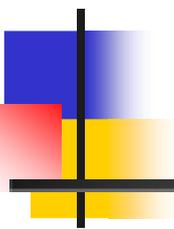

DESCARGAS ATMOSFÉRICAS

José Pissolato Filho

Lightning Books Published in 2000 - 2003

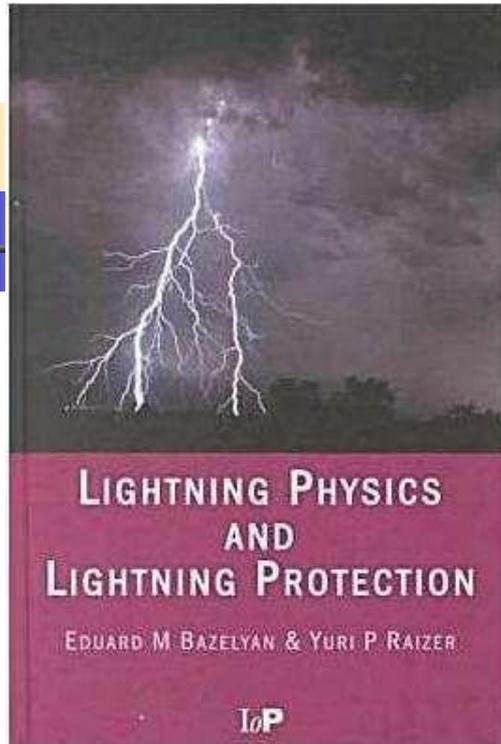

Bazelyan and Raizer (2000)

Institute of Physics (IoP)

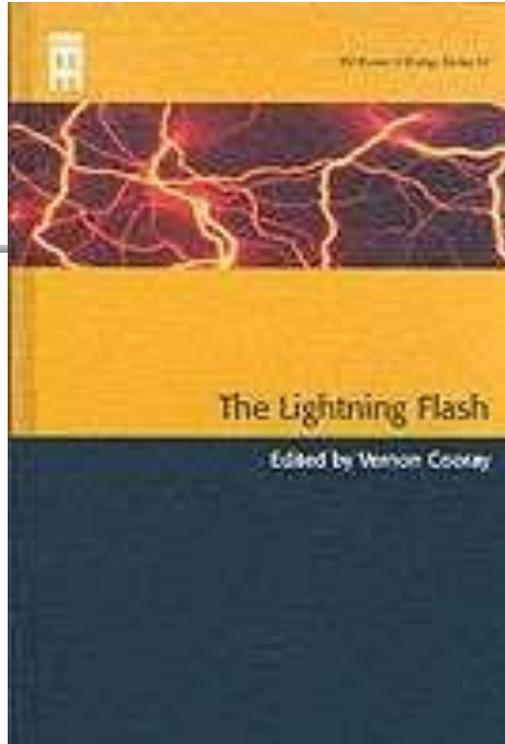

Cooray, ed. (2003)

The Institution of
Electrical Engineers (IEE)

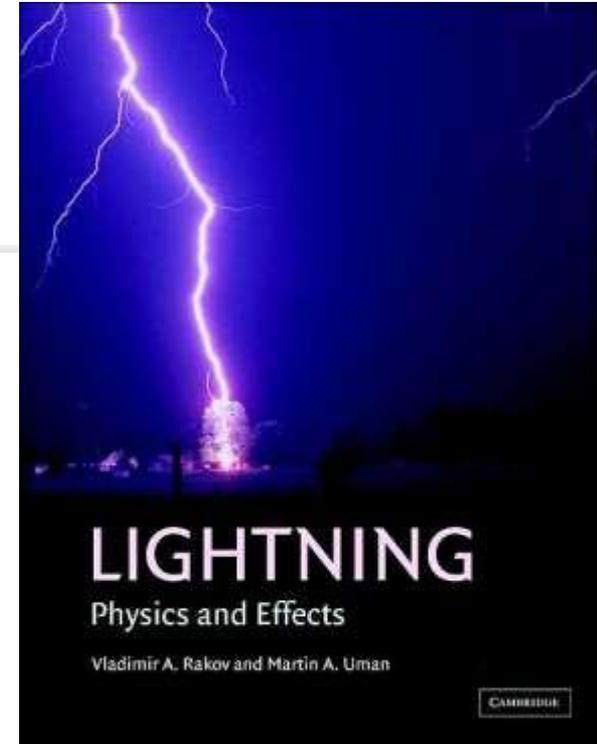

Rakov and Uman (2003)

Cambridge University Press

Over 700 journal papers on various aspects of lightning and its effects have been published since May 2002.



The physics of lightning



Joseph R. Dwyer^{a,*}, Martin A. Uman^b

^a Department of Physics and Space Sciences, Florida Institute of Technology, Melbourne, FL 32901, USA

^b Department of Electrical and Computer Engineering, University of Florida, Gainesville, FL 32611, USA

ARTICLE INFO

Article history:

Accepted 25 September 2013

Available online 9 October 2013

editor: M.P. Kamionkowski

ABSTRACT

Despite being one of the most familiar and widely recognized natural phenomena, lightning remains relatively poorly understood. Even the most basic questions of how lightning is initiated inside thunderclouds and how it then propagates for many tens of kilometers have only begun to be addressed. In the past, progress was hampered by the unpredictable and transient nature of lightning and the difficulties in making direct measurements inside thunderstorms, but advances in instrumentation, remote sensing methods, and rocket-triggered lightning experiments are now providing new insights into the physics of lightning. Furthermore, the recent discoveries of intense bursts of X-rays and gamma-rays associated with thunderstorms and lightning illustrate that new and interesting physics is

Total Lightning Flash Density

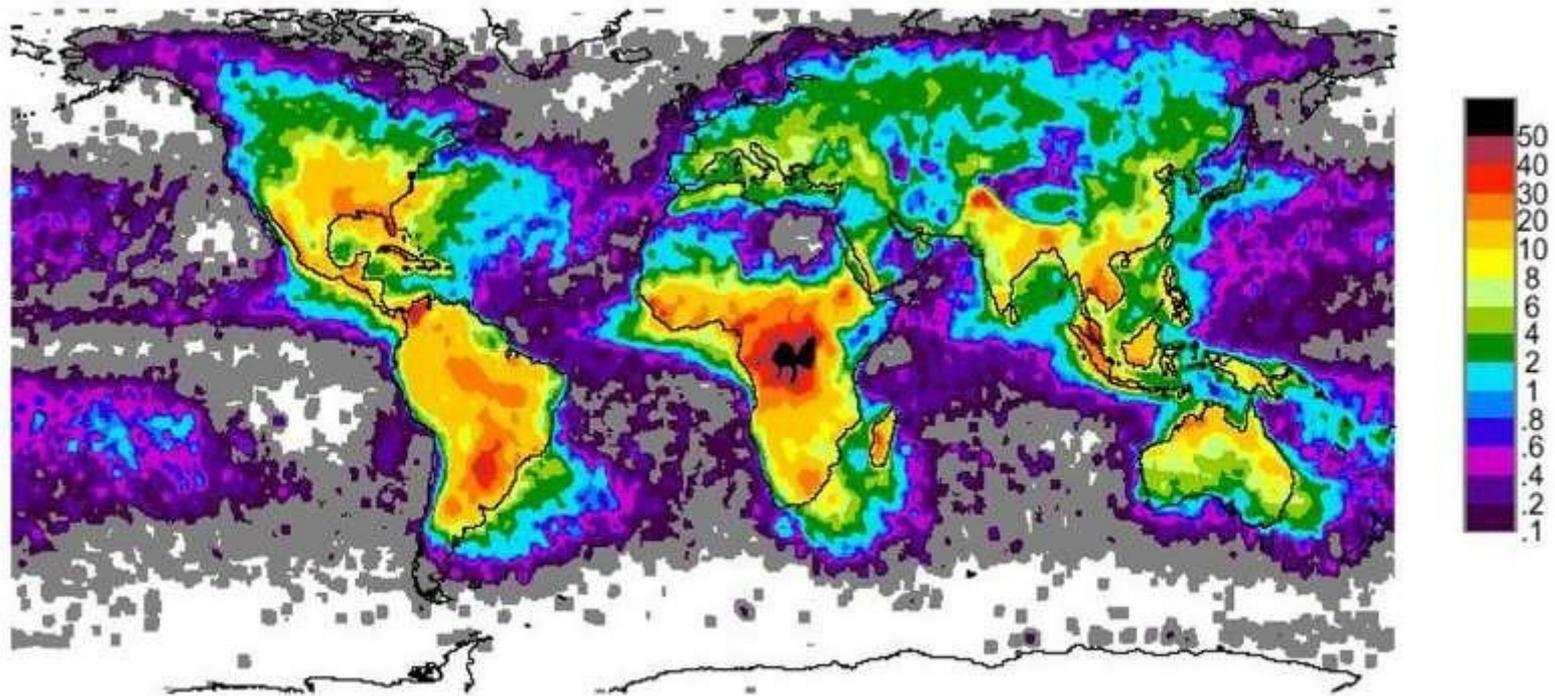

A global map of total lightning flash density (per square kilometer per year) based on data from two satellite detectors, **Optical Transient Detector** (OTD, 5 years) and **Lightning Imaging Sensor** (LIS, 3 years).

Grey areas: 0.01-0.1 km⁻²yr⁻¹; white areas: <0.01 km⁻²yr⁻¹.





"The Hit" ©1993 Niagara Mohawk Power Corporation

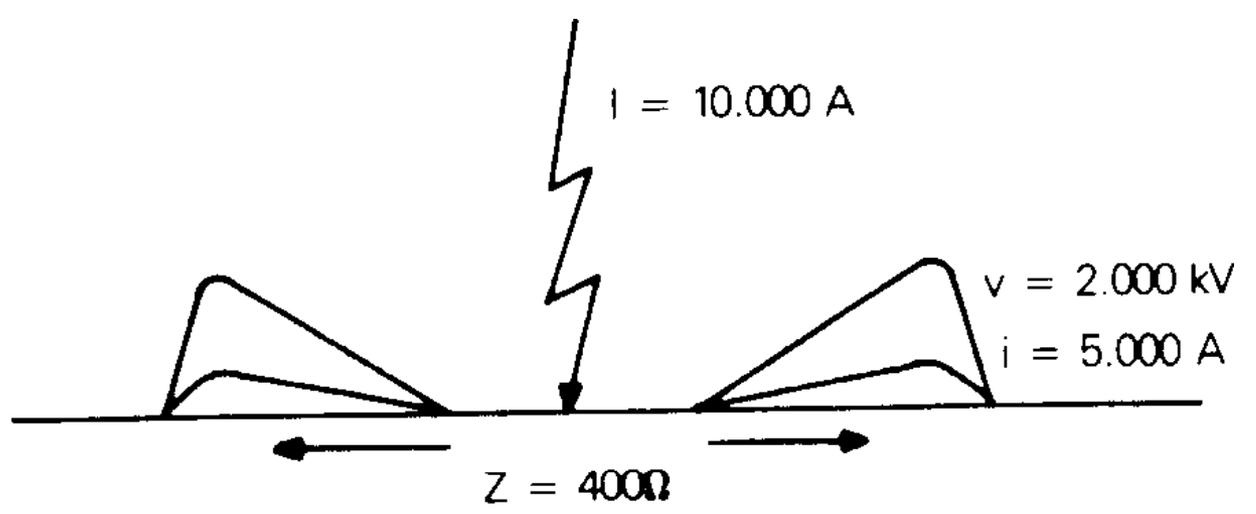
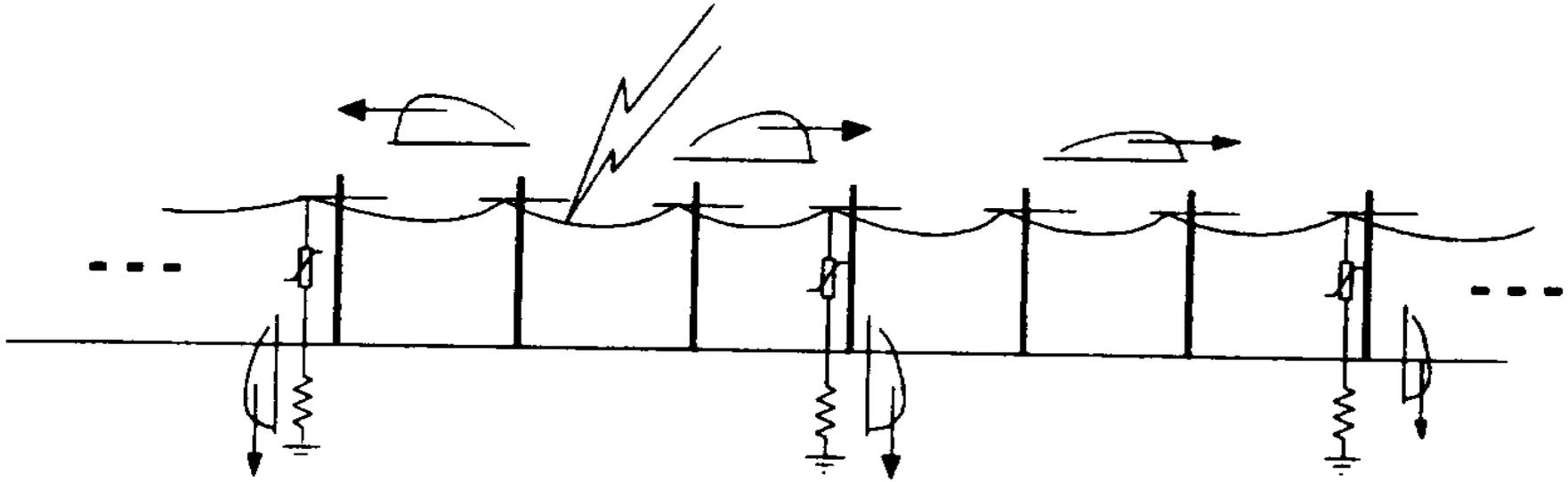



The Electromagnetic Spectrum

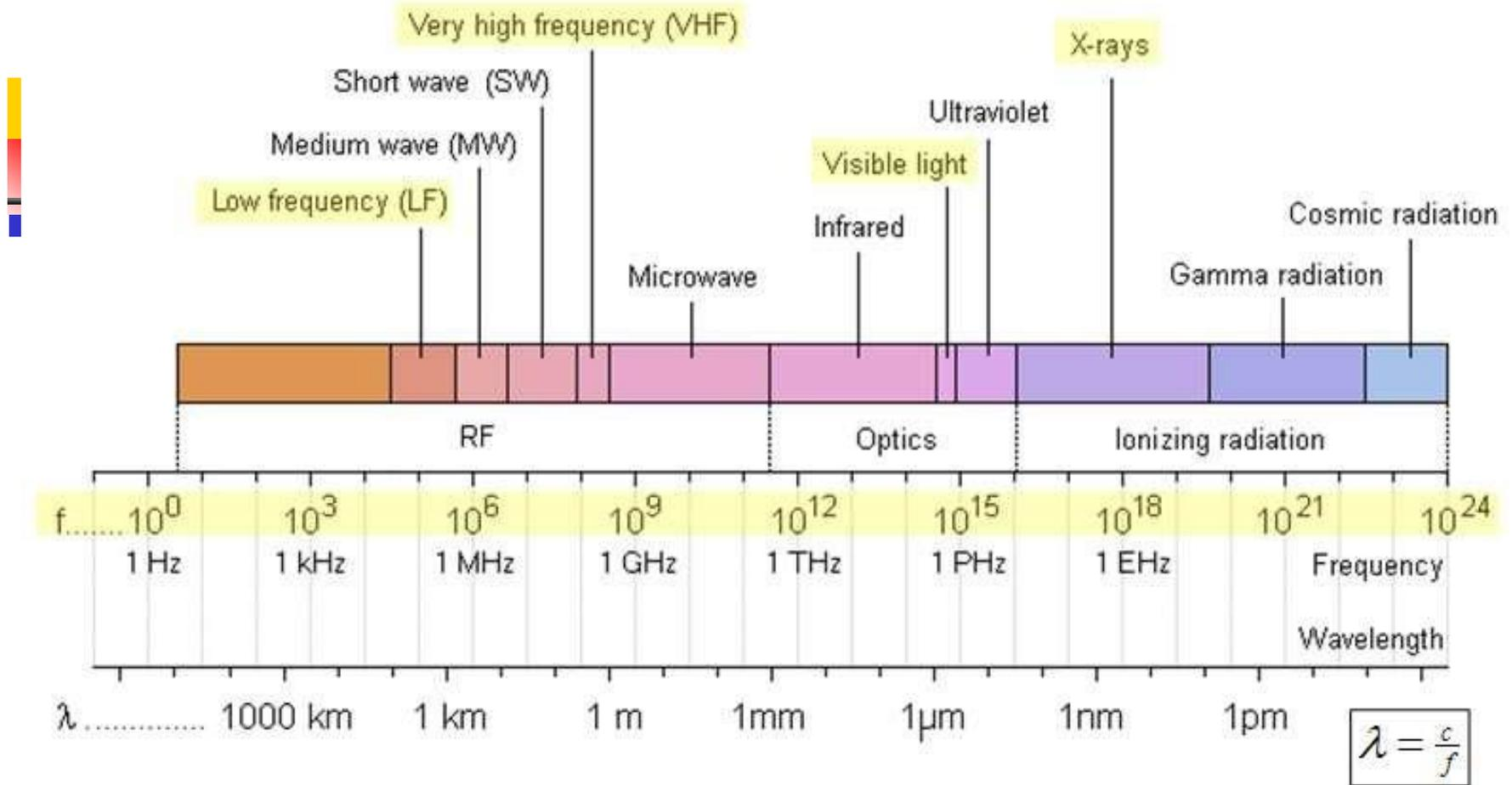

Various lightning processes emit electromagnetic signals with a peak in the radio-frequency spectrum at 5 to 10 kHz, when observed at distances beyond 50 km or so. At frequencies higher than that of the spectrum peak, the spectral amplitude varies approximately inversely proportional to the frequency up to 10 MHz or so and inversely proportional to the square root of frequency from about 10 MHz to 10 GHz (Cianos et al. 1973).

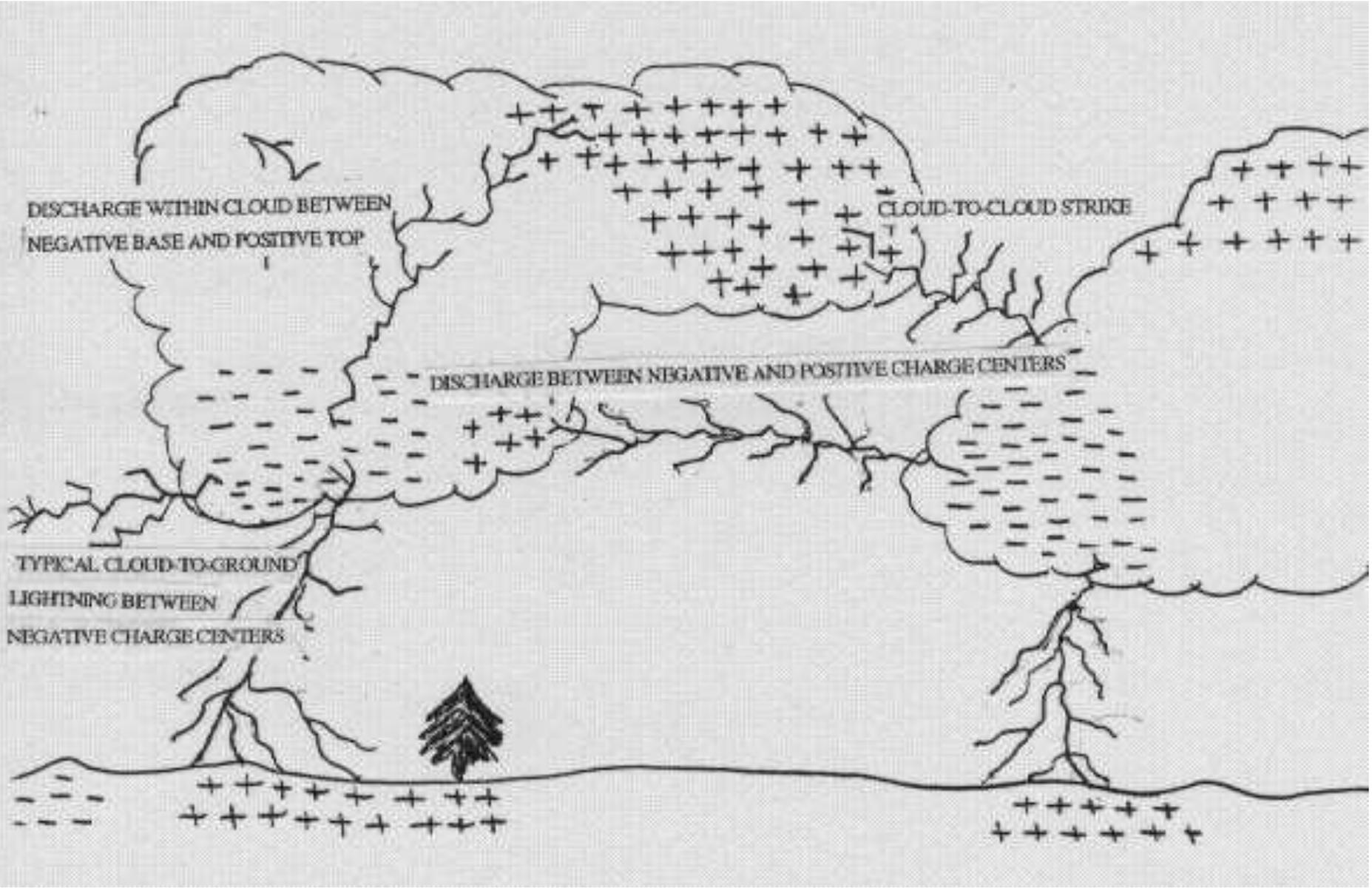

DISCHARGE WITHIN CLOUD BETWEEN
NEGATIVE BASE AND POSITIVE TOP

CLOUD-TO-CLOUD STRIKE

DISCHARGE BETWEEN NEGATIVE AND POSITIVE CHARGE CENTERS

TYPICAL CLOUD-TO-GROUND
LIGHTNING BETWEEN
NEGATIVE CHARGE CENTERS

Lightning Stroke Phenomena

Charge Distribution at Various Stages of Lightning Discharge

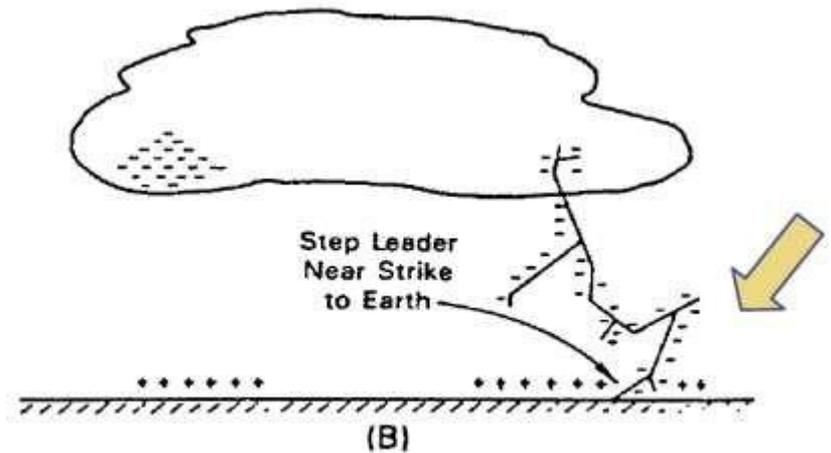
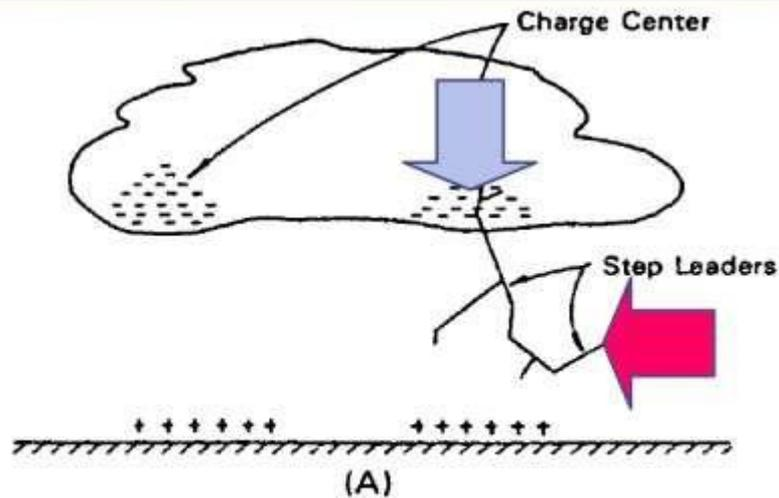

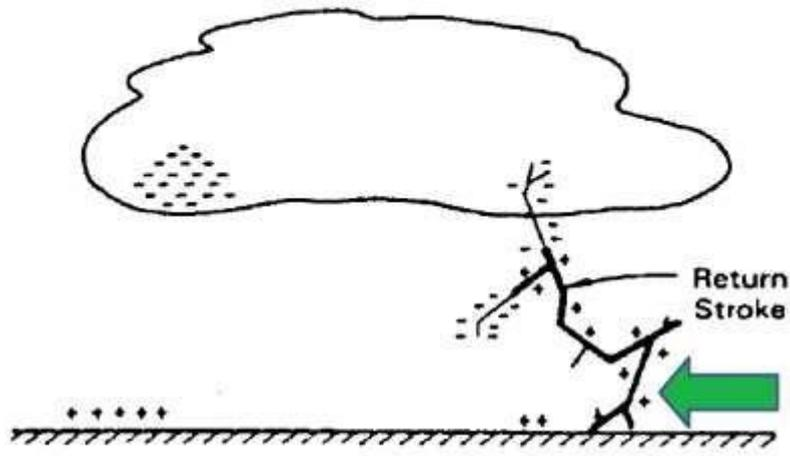

(C)

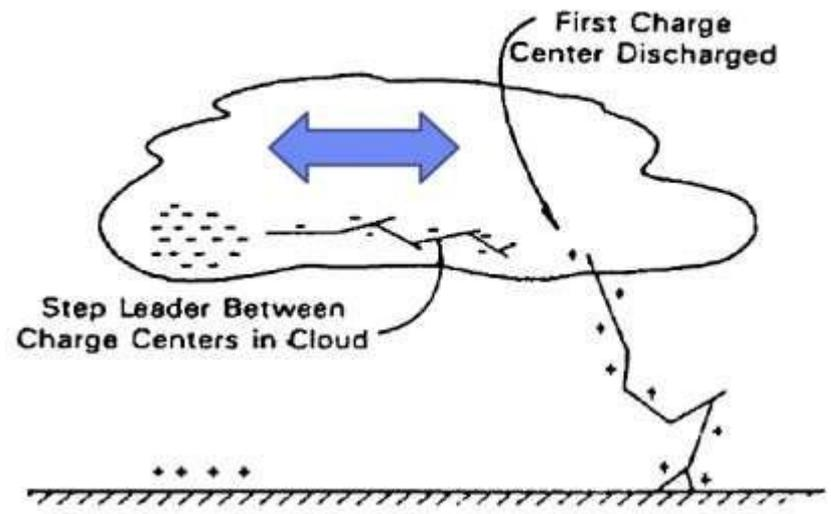

(D)

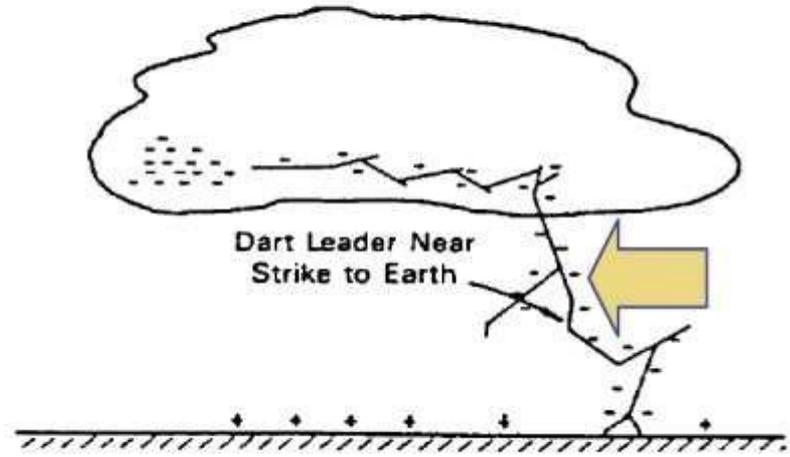

(E)

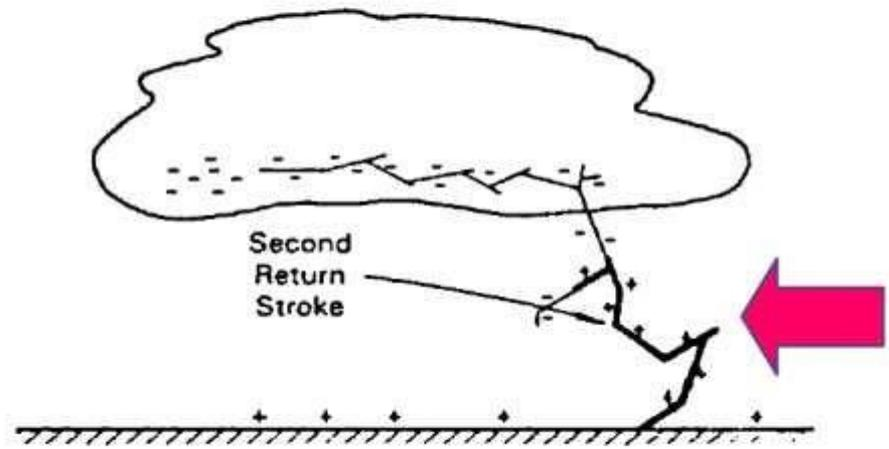

(F)

Adapted from: *Electrical Transmission and Distribution Reference Book*, by Central Station Engineers of the Westinghouse Electric Corporation, East Pittsburgh, Pennsylvania, Fourth Edition, 1964.

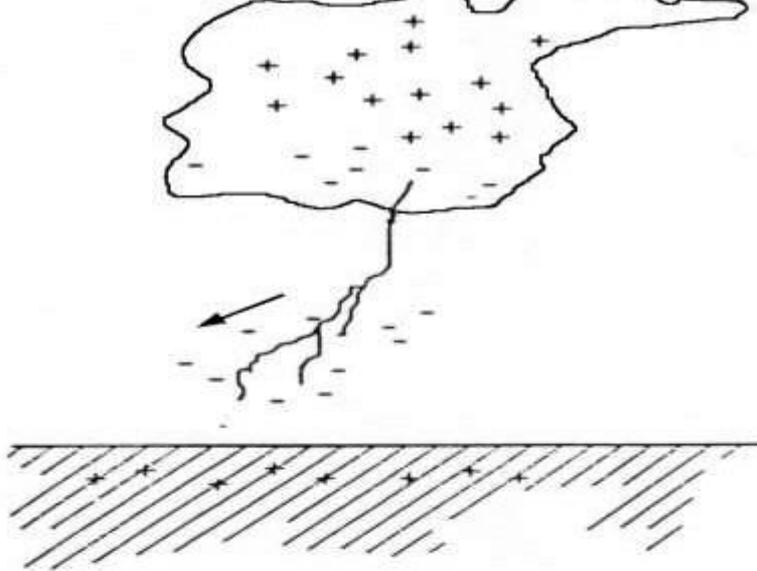

(a) Downward Negative Lightning

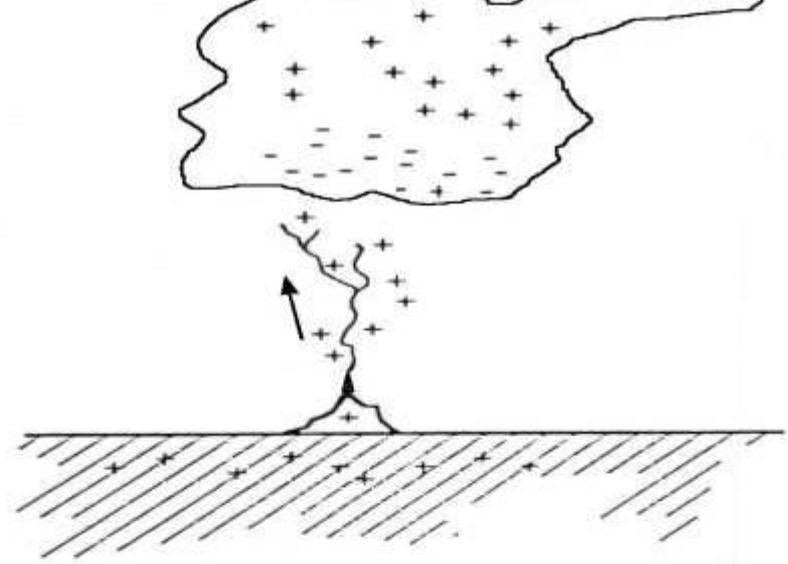

(b) Upward Negative Lightning

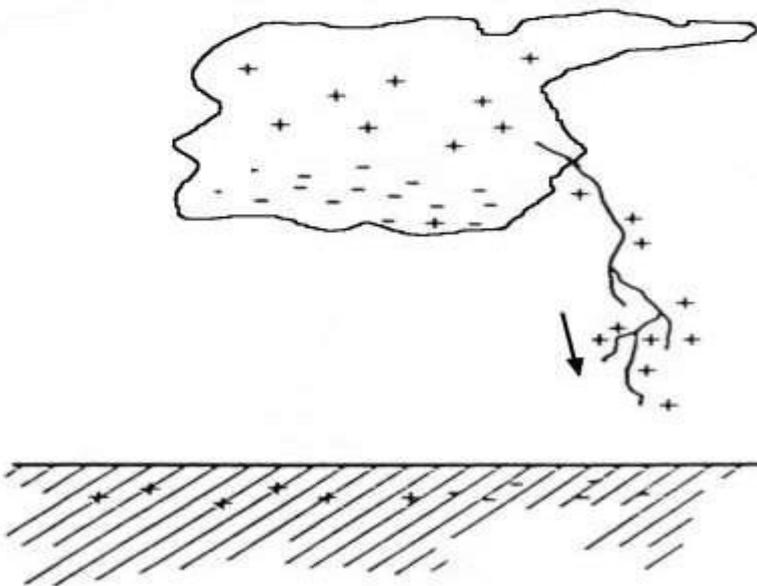

(c) Downward Positive Lightning

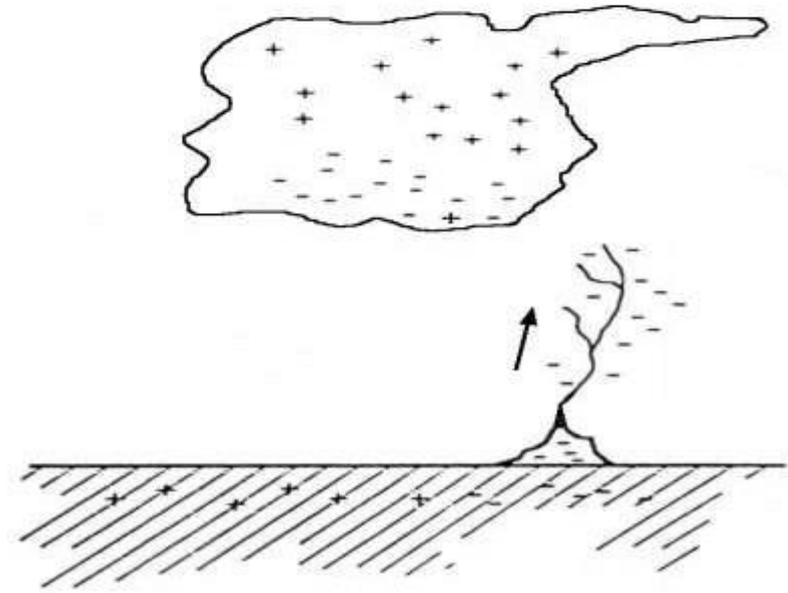

(d) Upward Positive Lightning

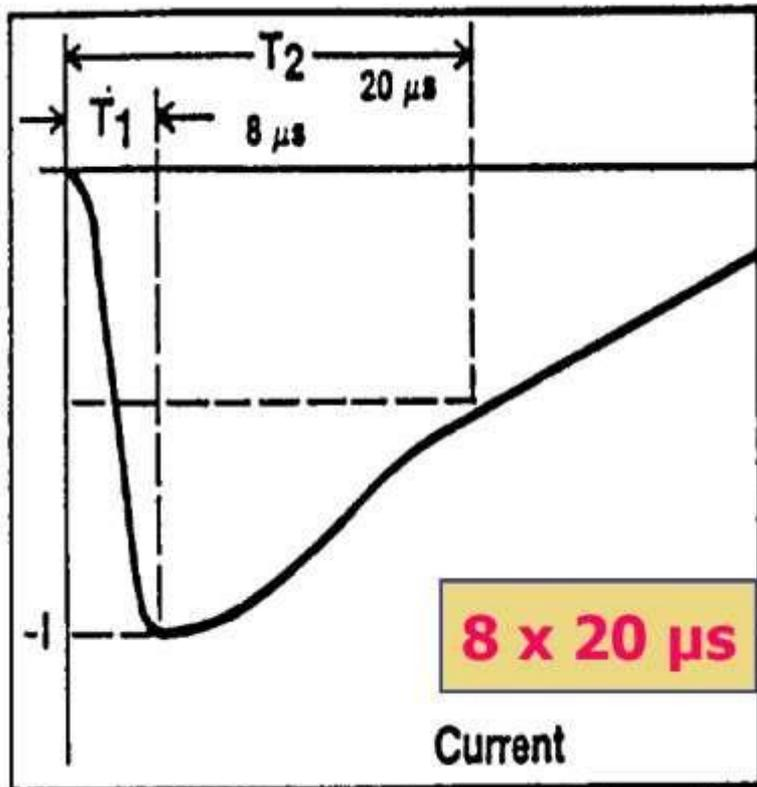

A

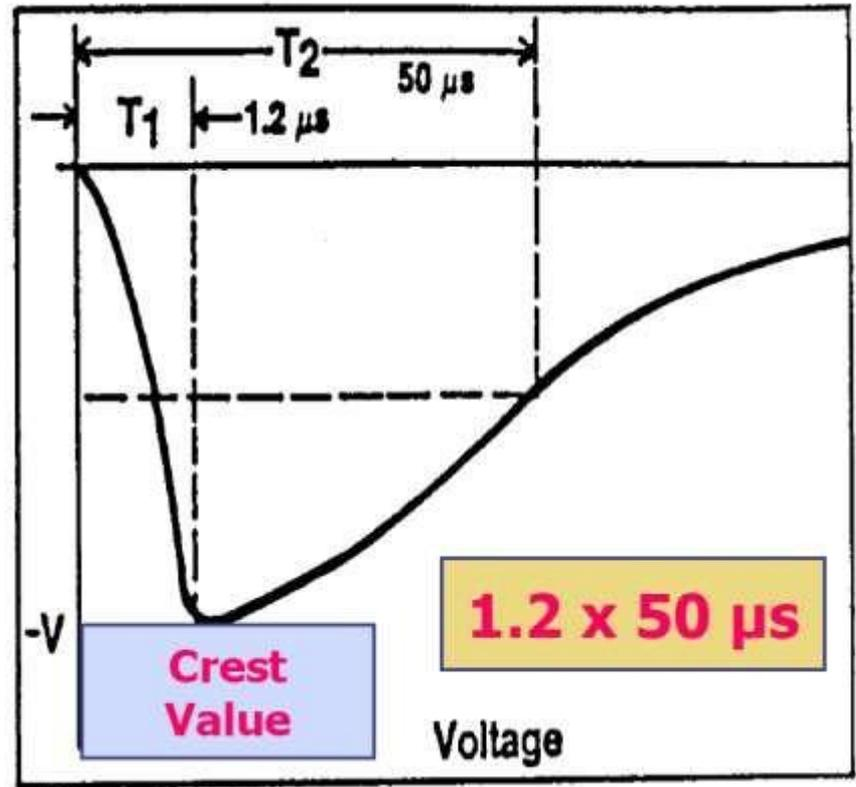

B

T_1 : Rise Time

T_2 : Time to Half value







Video frame of a lightning strike to an aircraft on takeoff from the Kamatsu Air Force Base, Japan, during winter. Courtesy of Z. I. Kawasaki

Overview of major triggered-lightning programs (also experiments in Germany, Indonesia, and Russia)

Experimental site	Height above sea level, m	Years of operation	Wire material	Location of wire spool	Selected references
Saint Privat d' Allier, France	1100	1973-1996	Steel or copper	Ground or rocket	Fieux et al. (1978), SPARG (1982)
Kanokugata, Hokuriku coast, Japan	0	1977-1985	Steel	Ground	Horii (1982), Kito et al. (1985)
Langmuir Laboratory, New Mexico	3230	1979-present	Steel	Ground	Hubert et al. (1984), Idone et al. (1984)
KSC, Florida (south of Melbourne, Florida in 1983)	0	1983-1991	Copper	Rocket	Eybert-Berard et al. (1986,1988), Willett(1992)
Okushishiku, Japan	930	1986-1998	Steel	Ground or rocket	Nakamura et al. (1991, 1992)
Four sites in northern and southeastern China	Various	1989-present	Steel or copper	Ground or rocket	Liu et al. (1994), Liu and Zhang (1998)
Fort McClellan, Alabama	190	1991-1995	Copper	Rocket	Fisher et al. (1993), Morris et al. (1994)
Camp Blanding, Florida	20-25	1993-present	Copper	Rocket	Uman et al. (1997), Rakov et al. (1998, 2004)
Cachoeira Paulista, Brazil	570	1999-present	Copper	Rocket	Saba et al. (2000, 2003), Solorzano et al. (2002)

Classical Triggering

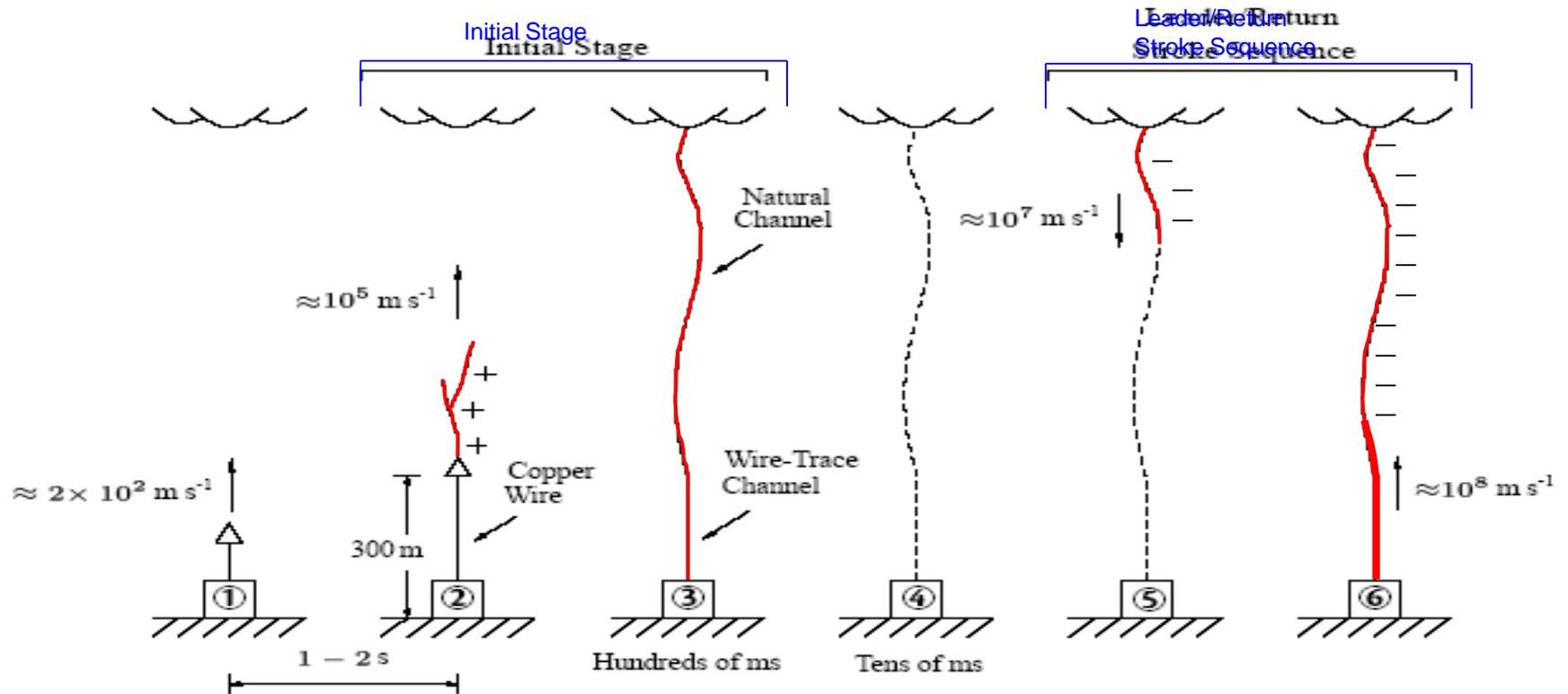

- ① Ascending Rocket
- ② Upward Positive Leader
- ③ Initial Continuous Current
- ④ No-Current Interval
- ⑤ Downward Negative Leader
- ⑥ Upward Return Stroke

Altitude Triggering

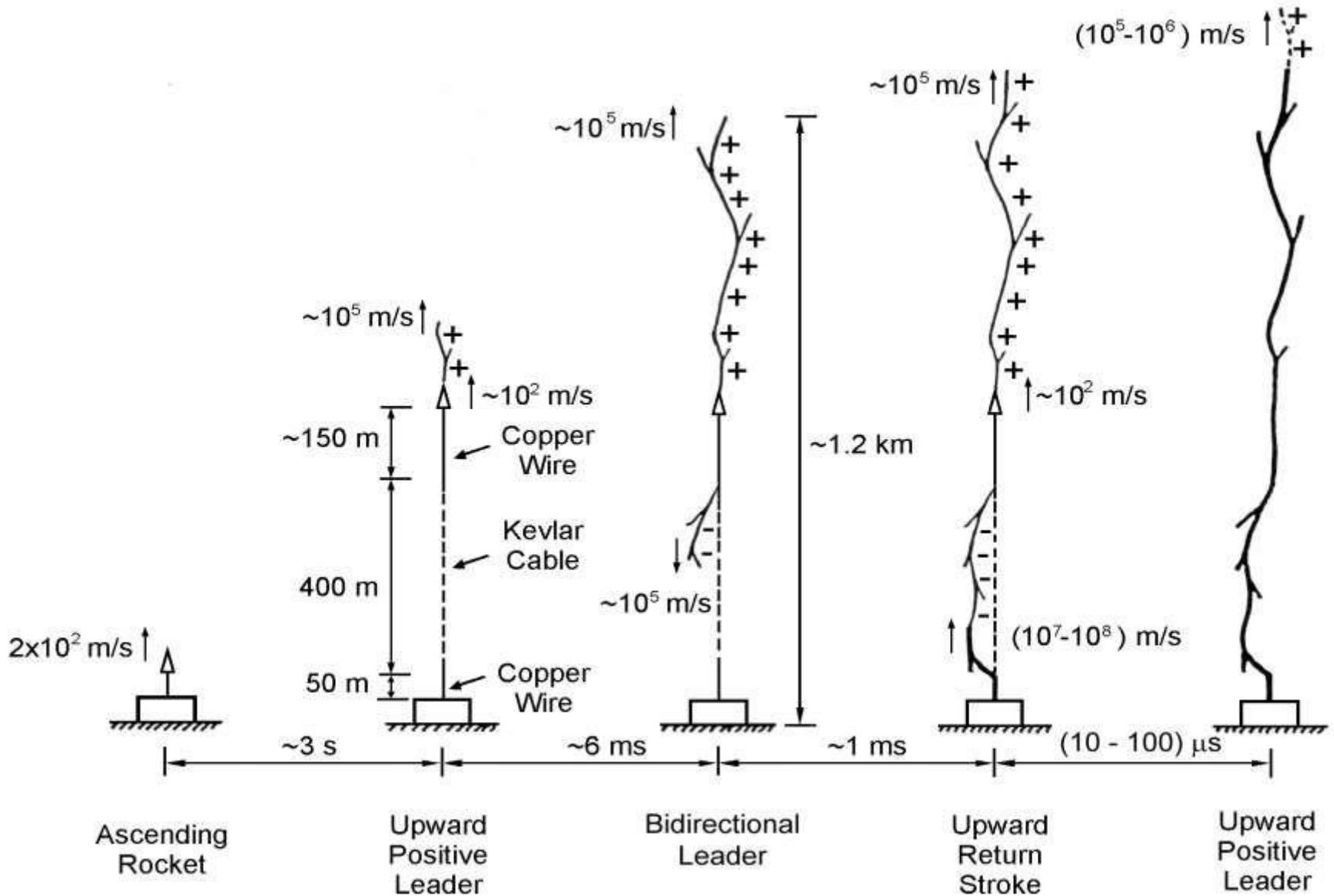

Plataforma



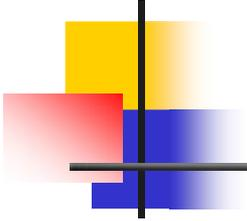

Foguetes



Foguetes



Foguetes





Field Mill



Campo elétrico de uma tempestade

Alerte du 24/01/2001. TIRS 12 et 13 NR

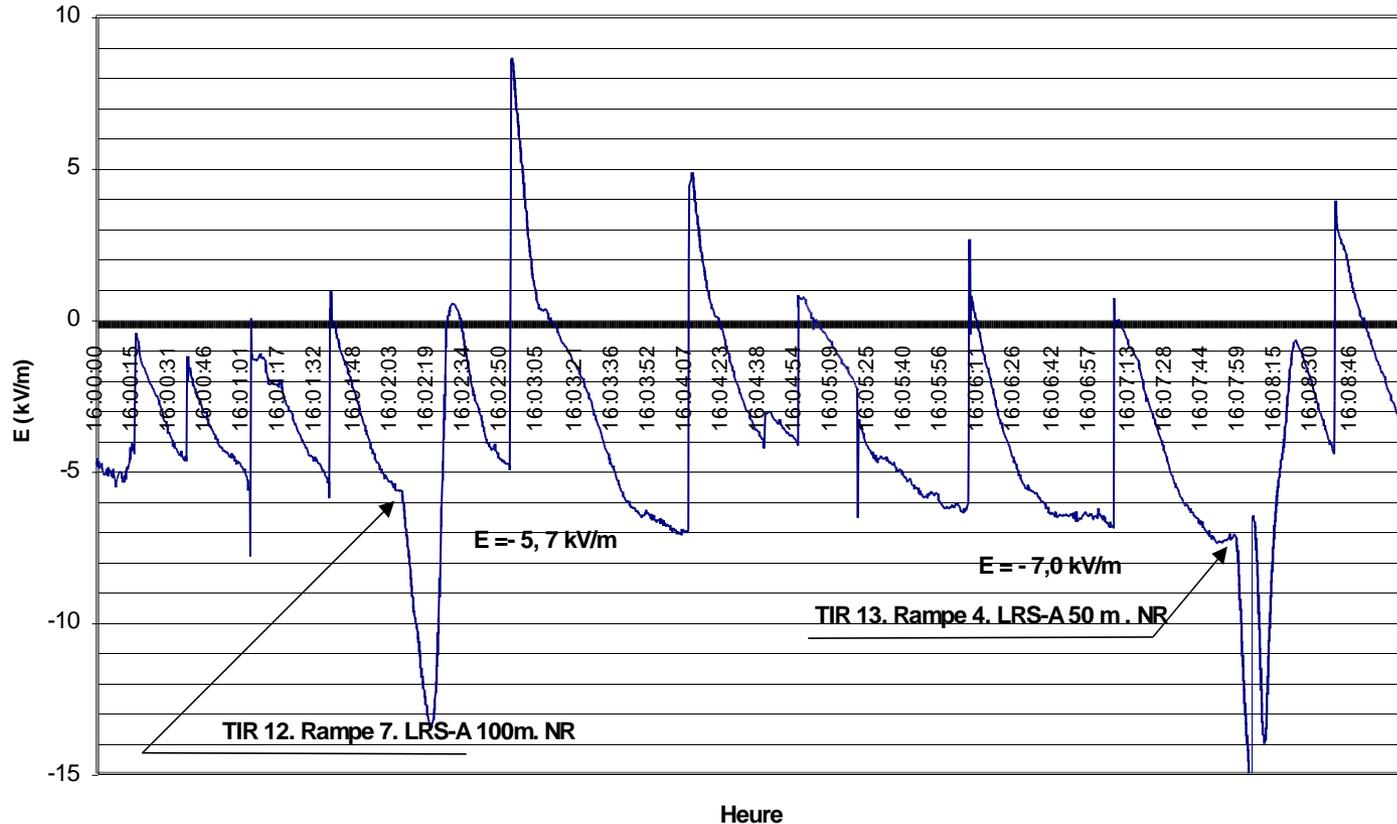

Medição de corrente da descarga

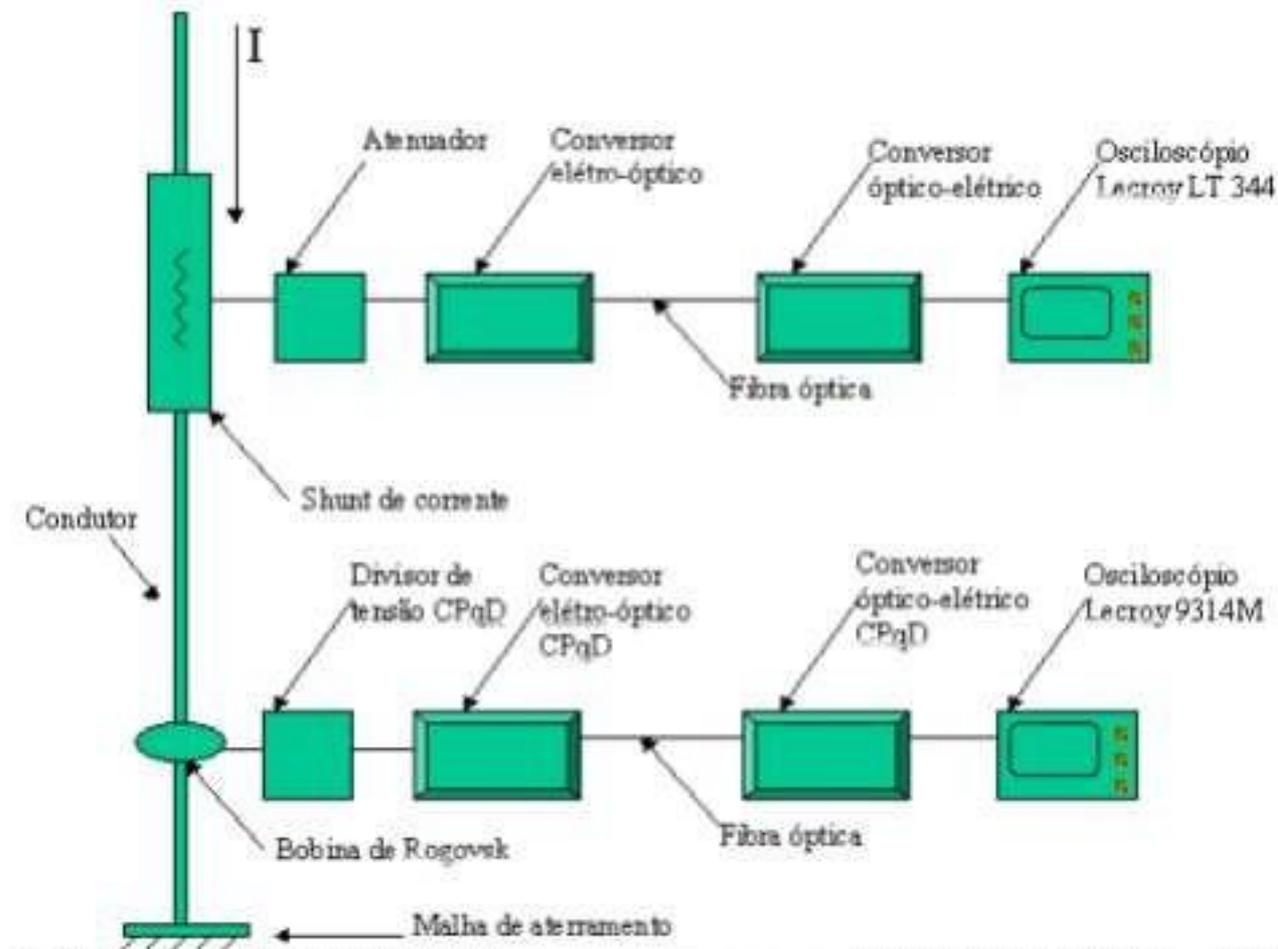

Sistema de Medição 2

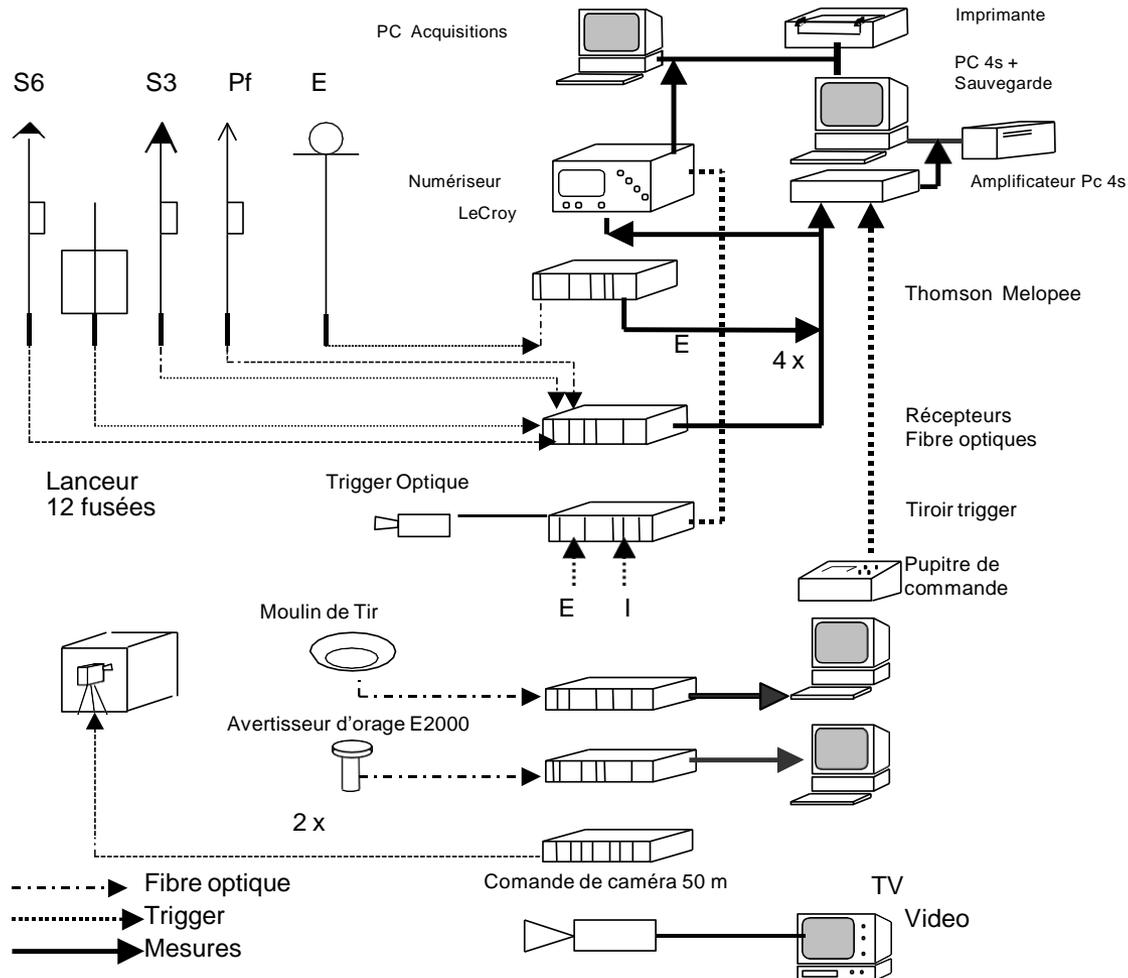

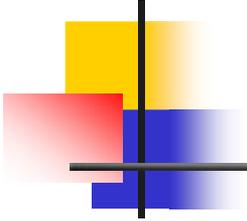

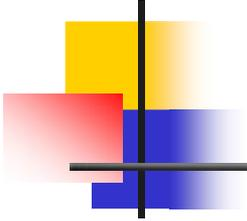

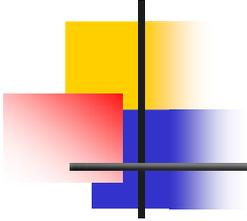

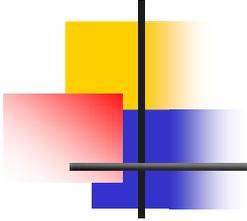

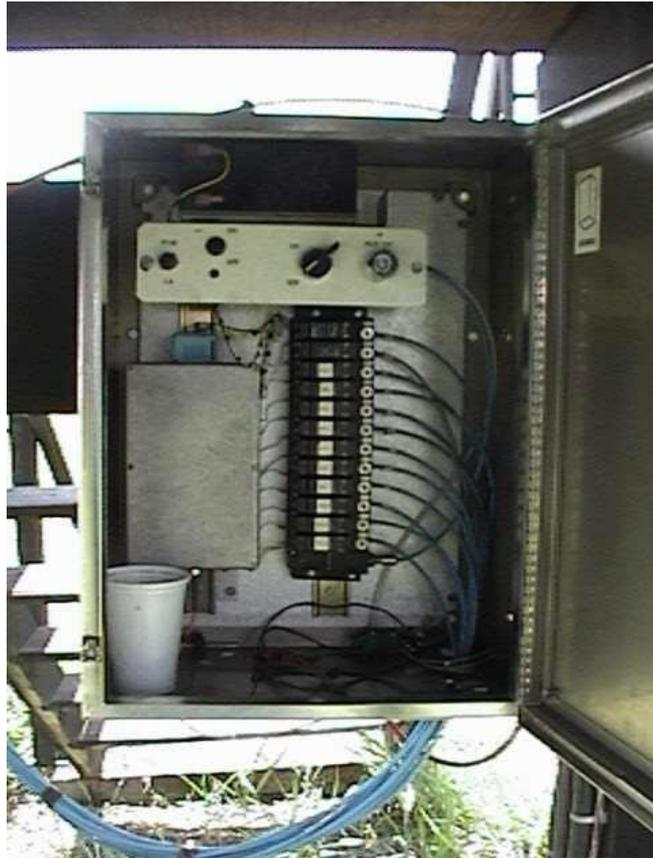
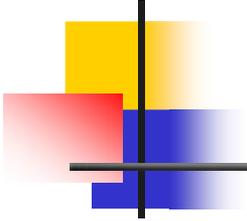

Filmagem



Foto de um raio trigado



Linha de telecomunicações em teste



Lançador Terrestre



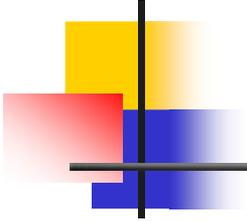

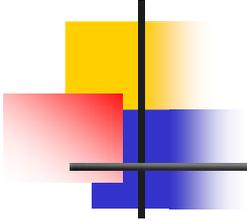



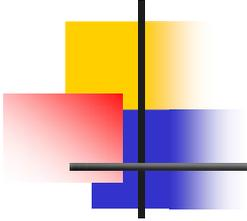

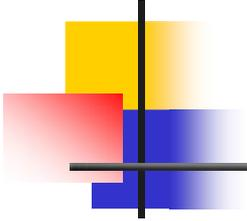

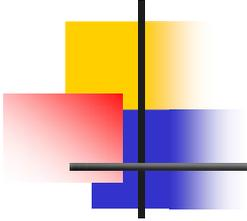

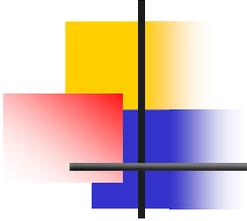

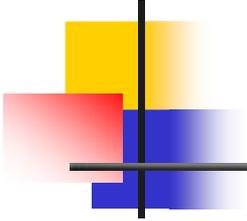

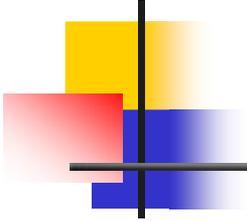

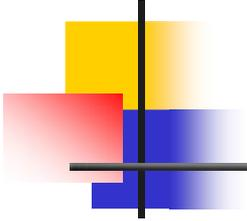

Raio Trigado 33



Corrente Tiro 33

12-Feb-02
15:34:10

Tir n° 33 type LRSA 60m-800m 11Février 2002 17h22 -9.30 kv/m

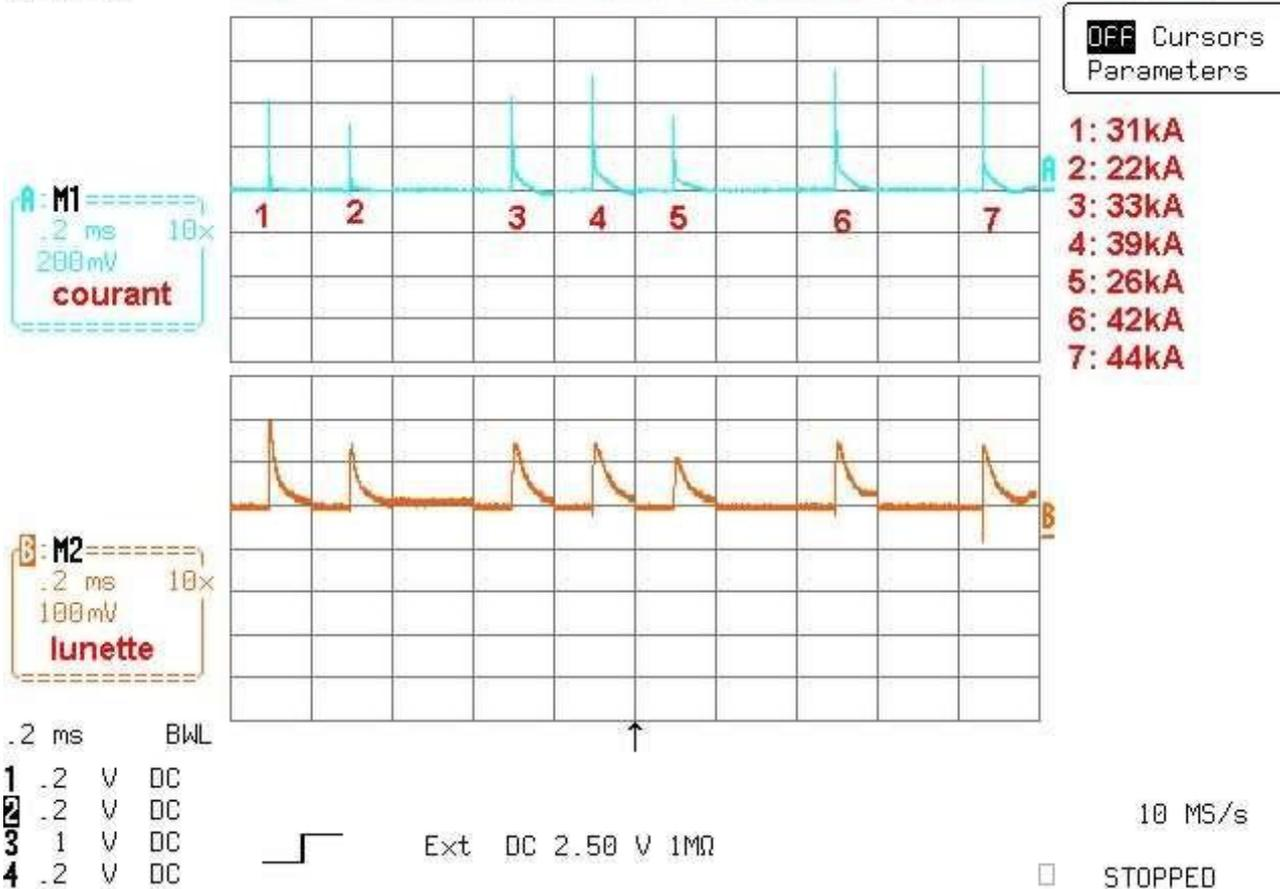



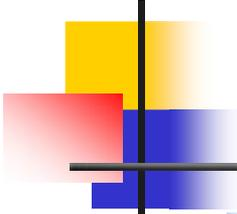







PM 3:06
JUL. 13 2003









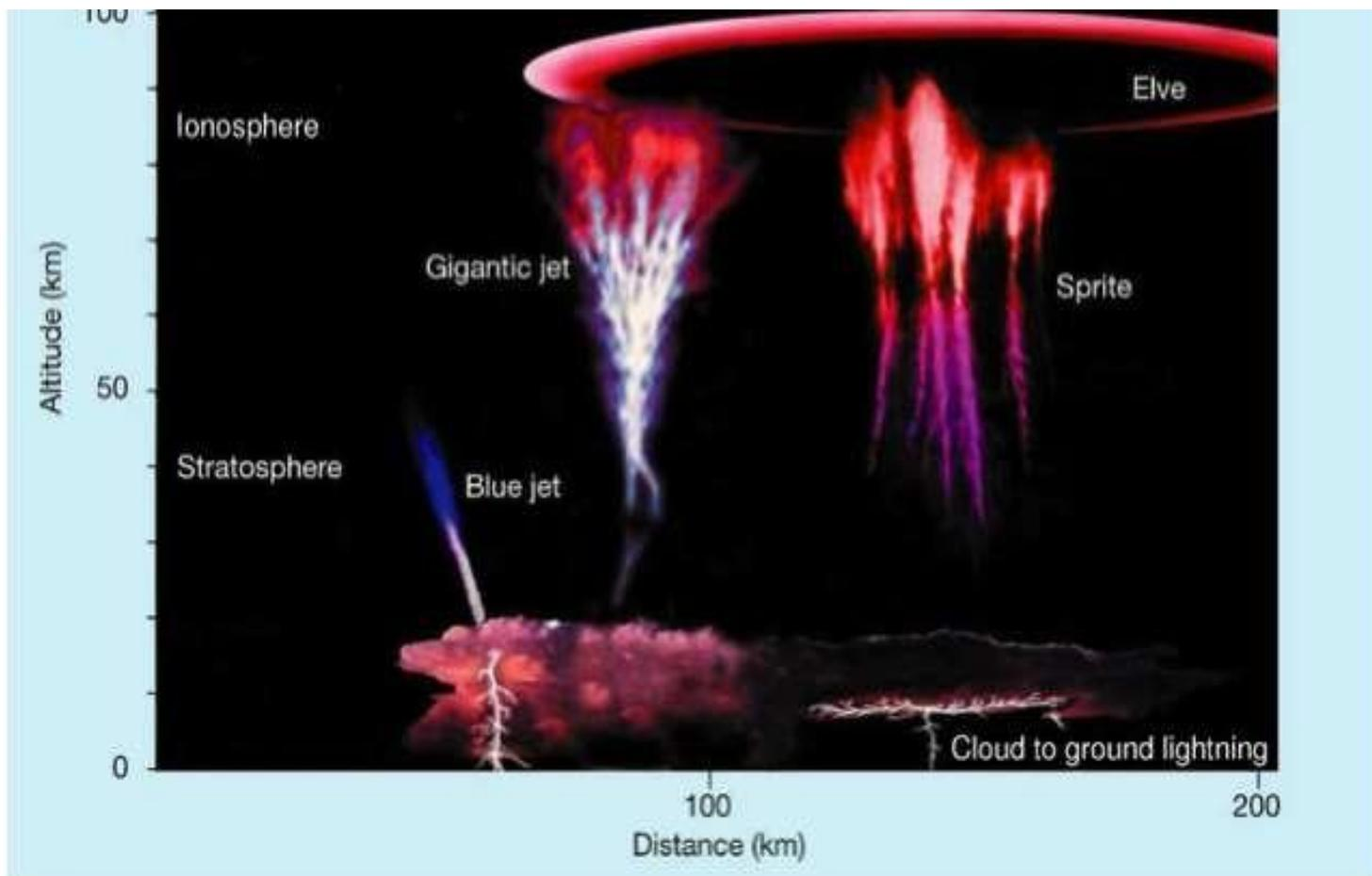
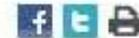

Figure 1.4: A cartoon of the “big picture” of TLEs showing sprites, jets, and elves (reproduced from Lyons et al. [2003]; Pasko [2003]).

13 November 2014 Last updated at 19:16 GMT



Climate change 'will make lightning strike more'



By Victoria Gill

Science reporter, BBC News

Global warming will significantly increase the frequency of lightning strikes, according to US research.

The research, **published in Science**, was carried out with the help of data from a US network of lightning detectors.

The teams says they have calculated how much each extra degree in temperature will raise the frequency of lightning.

"For every two lightning strikes in 2000, there will be three lightning strikes in 2100," said David Romps, at the University of California, Berkeley.



O carregamento das nuvens

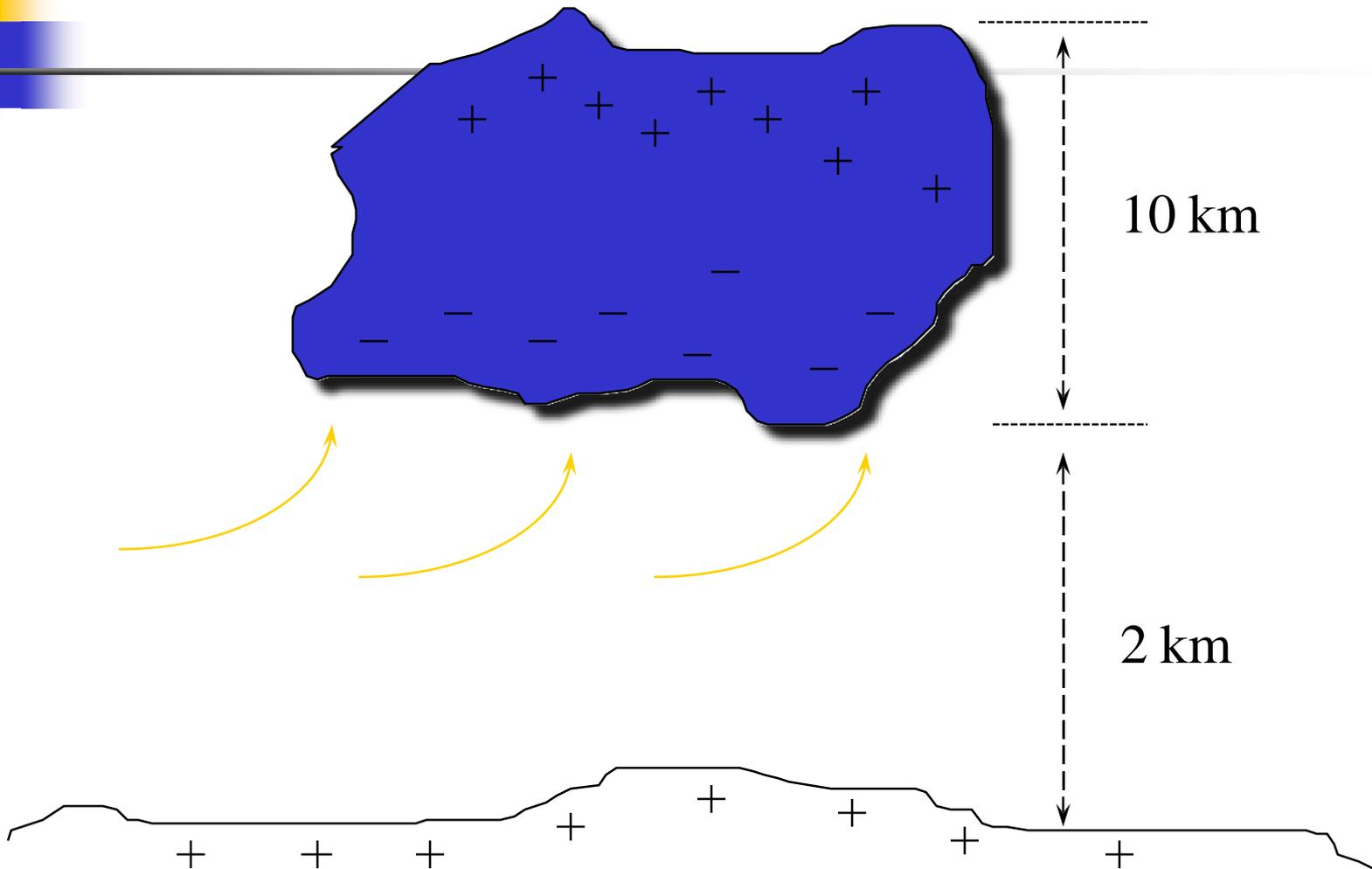

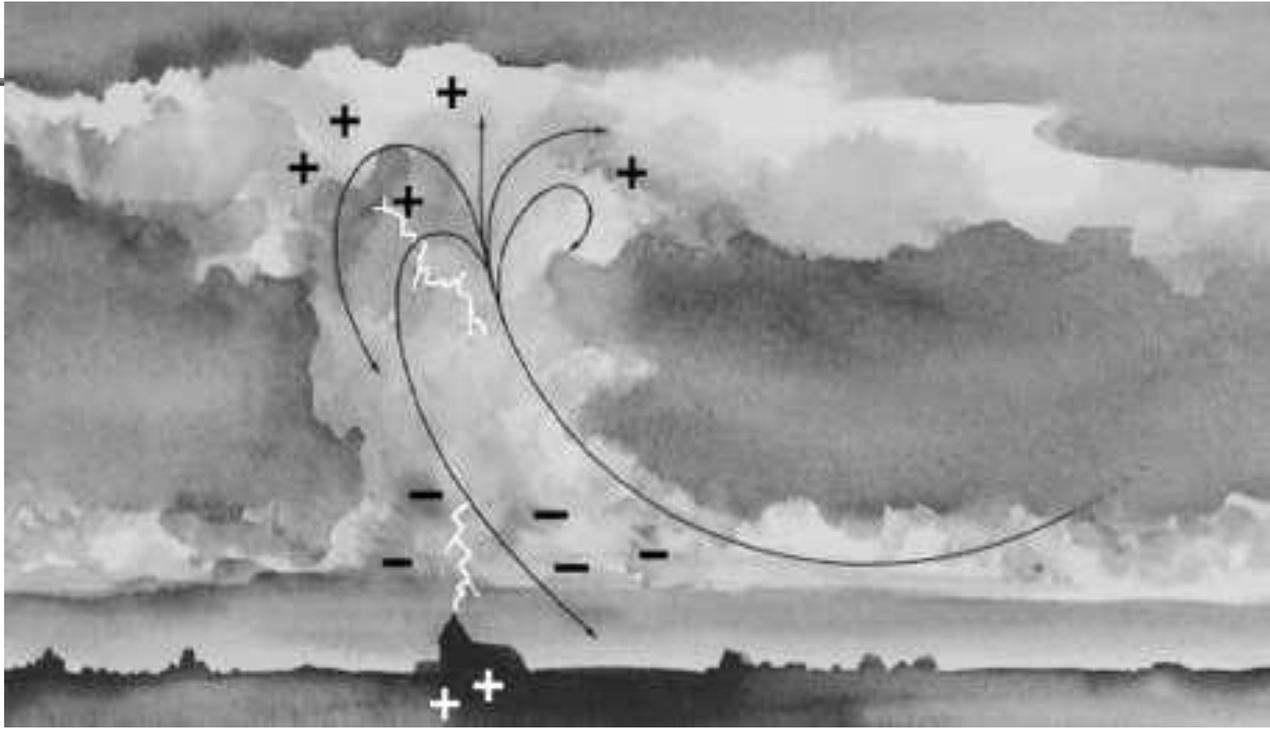
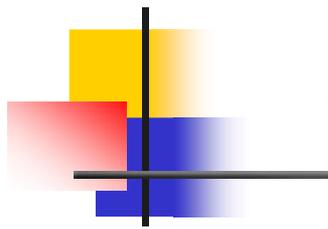

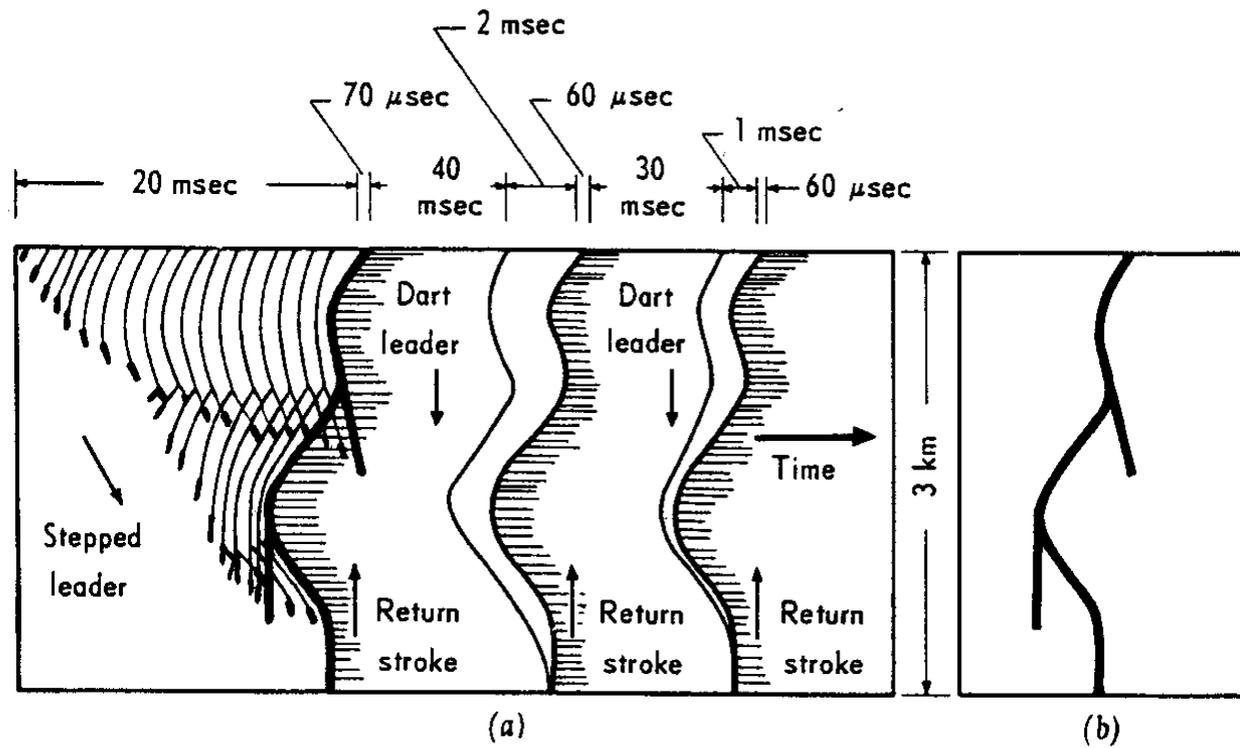
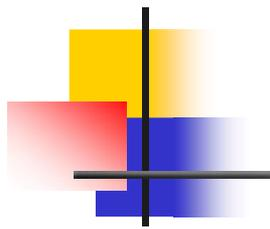

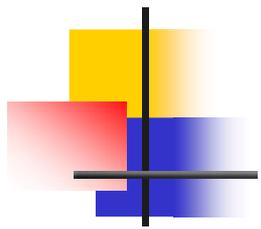

360 m

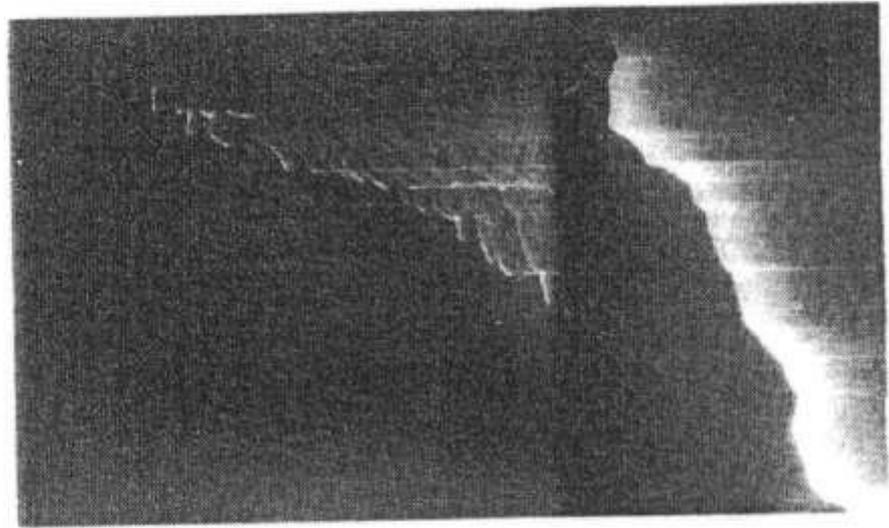

1 msec

Time →

Parâmetros típicos da descarga atmosférica

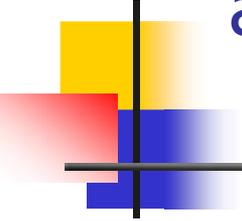

I_{PICO} (kA)	t_{PICO} (μ s)	% abaixo dos valores
3,5	1,0	1,0
34	7,0	50,0
102	30,0	99,0

Descargas Múltiplas

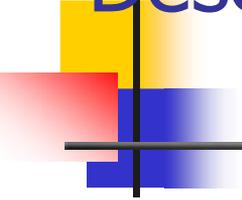

70% + de 1 componente
16% + de 2 componentes
10% + de 3 componentes
04% - 4 ou mais componentes

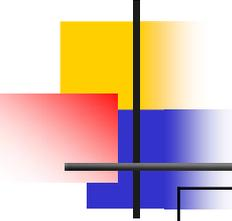

Nível ceráunico: número de dias de trovoada por ano

Local	Nível ceráunico
Alemanha	15 -35
Brasil	4 -140
Austrália	5 -107
África do Sul	5 -100
Itália	11 - 60
França	20 - 30

Densidade de descargas (descargas/ km²/ano)

Local

Densidade de descargas

São Paulo

1 - 9

México

1 - 9

Austrália

0,2 - 4

África do Sul

1 - 12

Itália

1 - 4

Alemanha

1 - 5,5

$$N_G = 0,04 \times T_D^{1,25}$$

$$N_G \approx 0,1 \times T_D$$

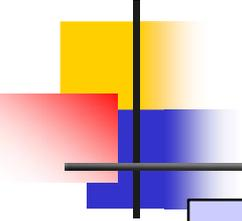

Tensões induzidas por descargas atmosféricas

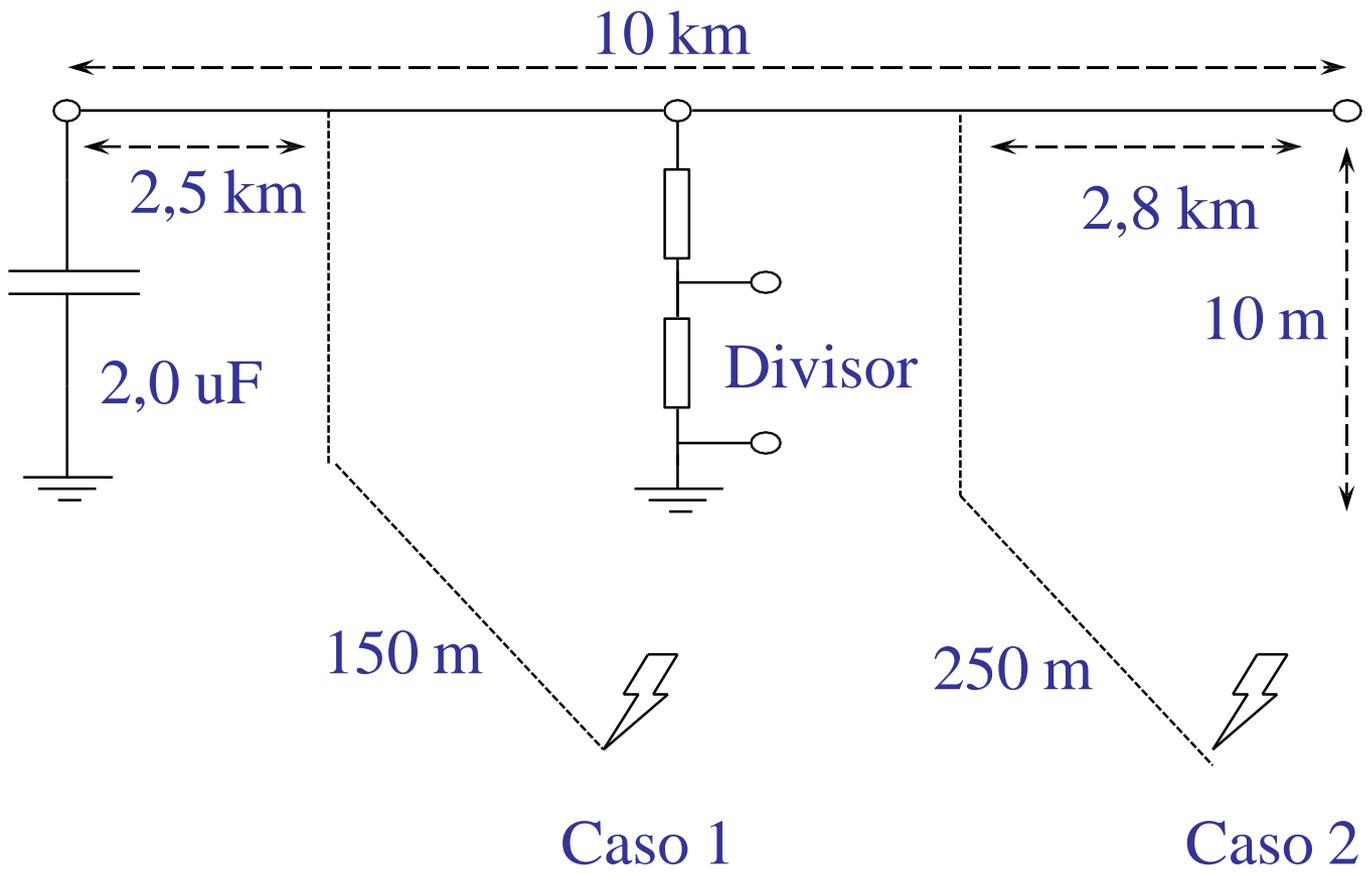

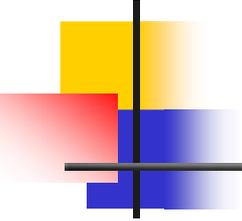

Casos estudados

	Caso 1	Caso 2
Valor de pico da corrente	14 kA	27 kA
Forma de onda	degrau	degrau
Velocidade da corrente	80 m/ μ s	40 m/ μ s

Caso 1

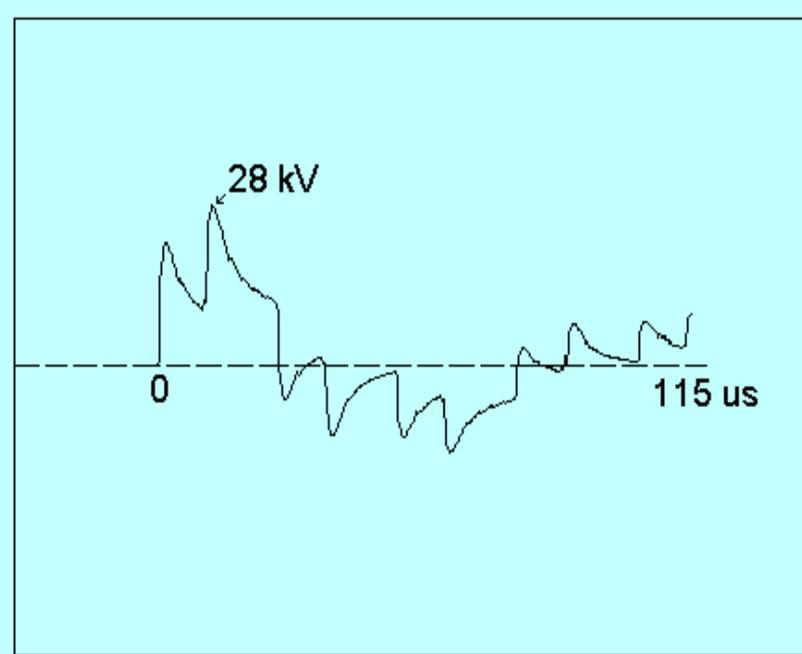
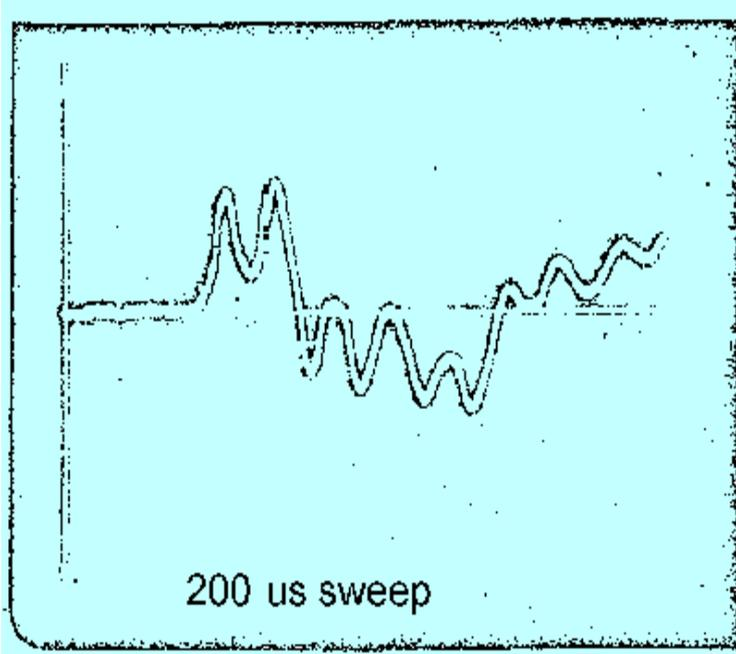

Caso 2

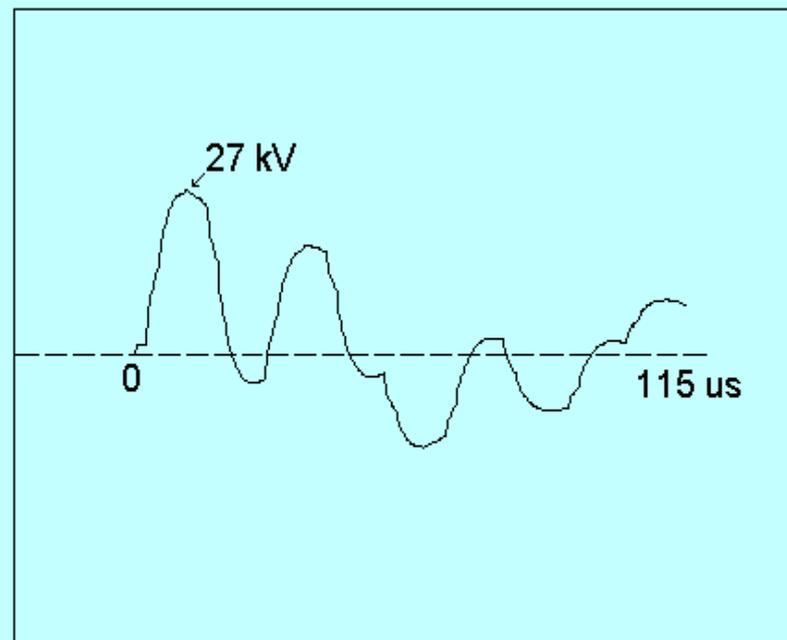
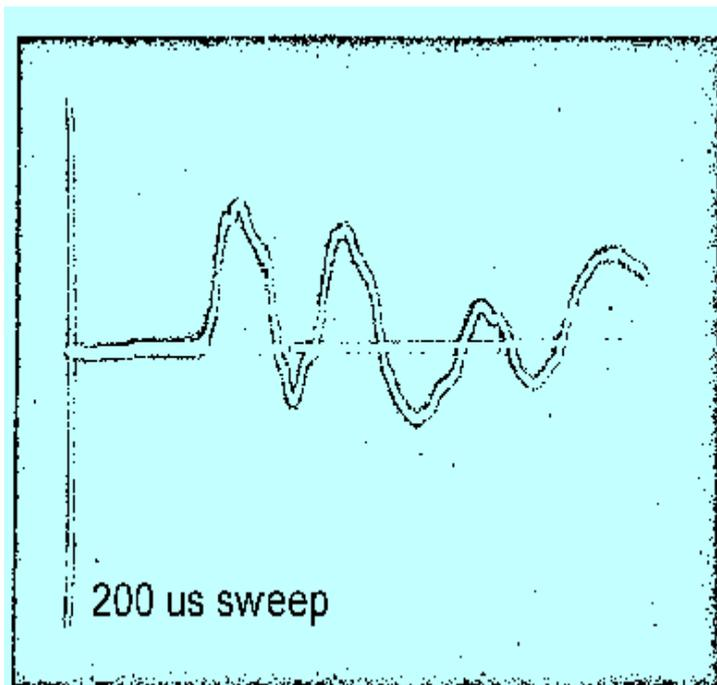

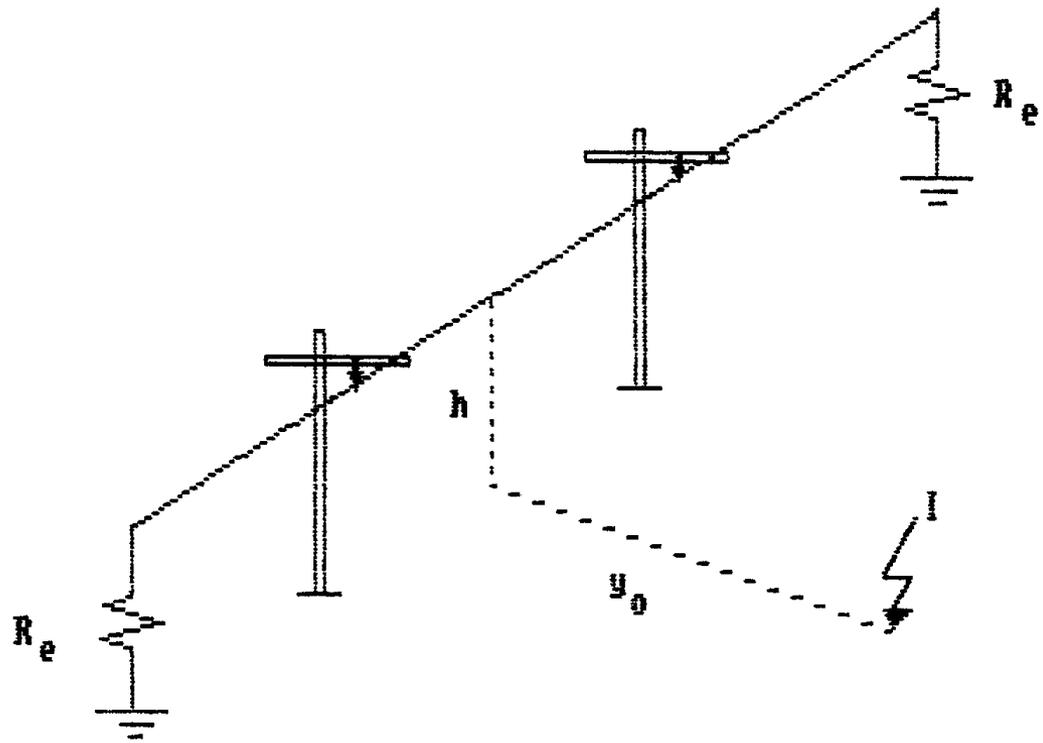
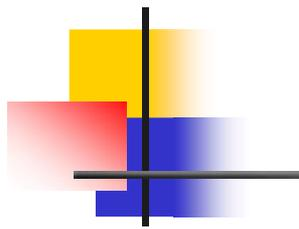

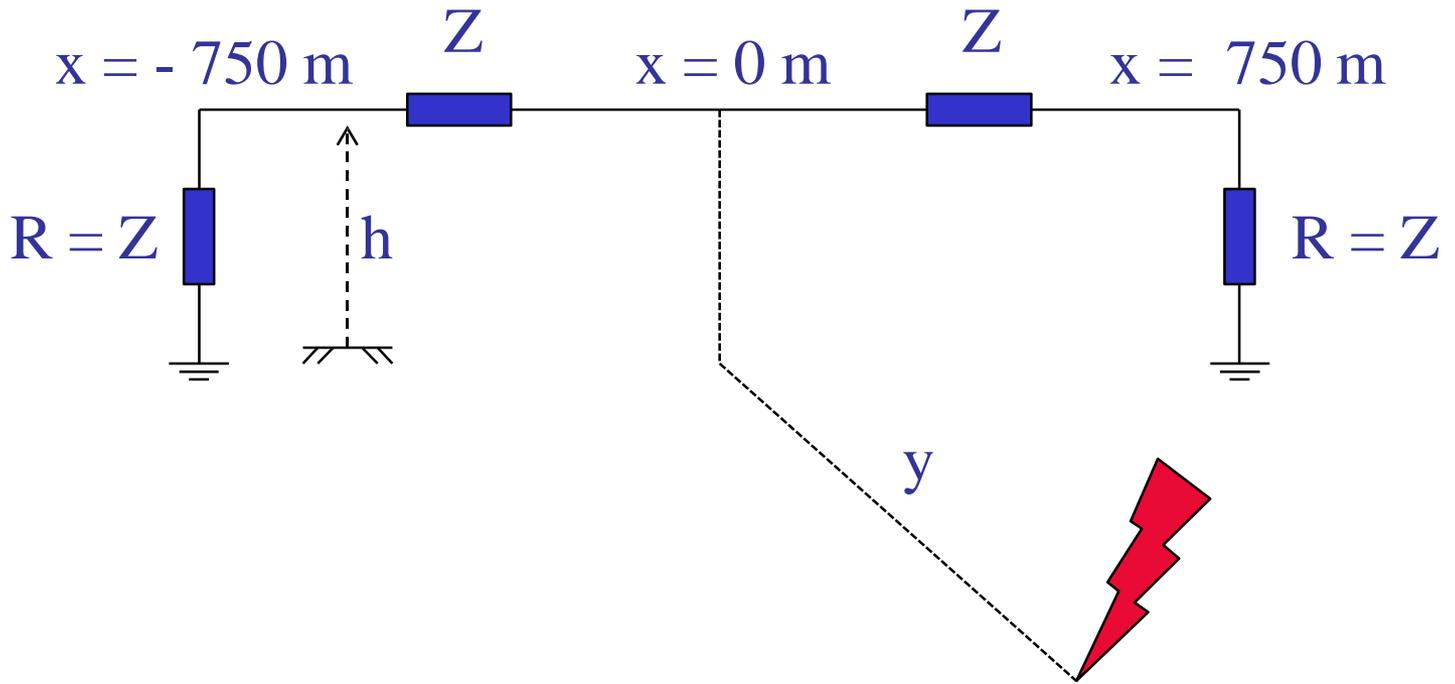
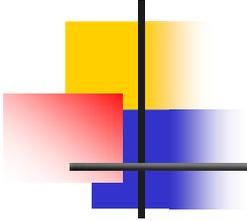

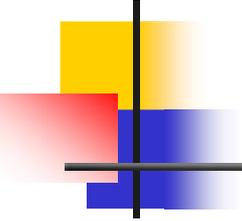

Na prática:

$$U_{\max} = \frac{30 \cdot I_0 \cdot h}{y}$$

